

HOST Application
Hyperterminal, VB, LabView, C++, C# ...

NYT1X-AP Rev 1.0
Nymotion LLC

Custom MMI
Keypad / LCD

HOOKUP COLOR CODE:

- BLUE = TCM-103
- RED = PIM2401/2403**
- GREEN = TCMC & PIM

**Servo Hookups
Brushed: A & B
Brushless: A, B & C

TCMC-103:
Step Motor (/64)
2A rms / 2.8A Peak

PIM2401:
BDC/DC SERVO or
STEP MOTOR (/256)
1A rms / 3A peak - 25 Watt

PIM2403:
BDC/DC SERVO or
STEP MOTOR (/256)
3A rms / 6A peak - 75 Watt

Halls (servo)

Encoder
(servo or stepper)

TRINAMIC: TCMC-103
TECHNOSOFT:
PIM2401
PIM2403

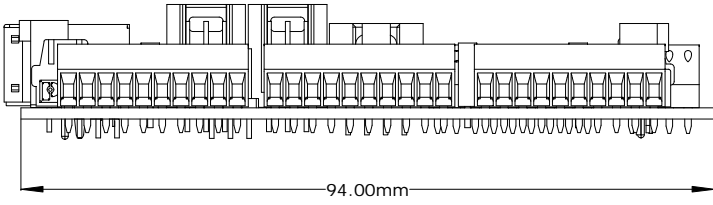
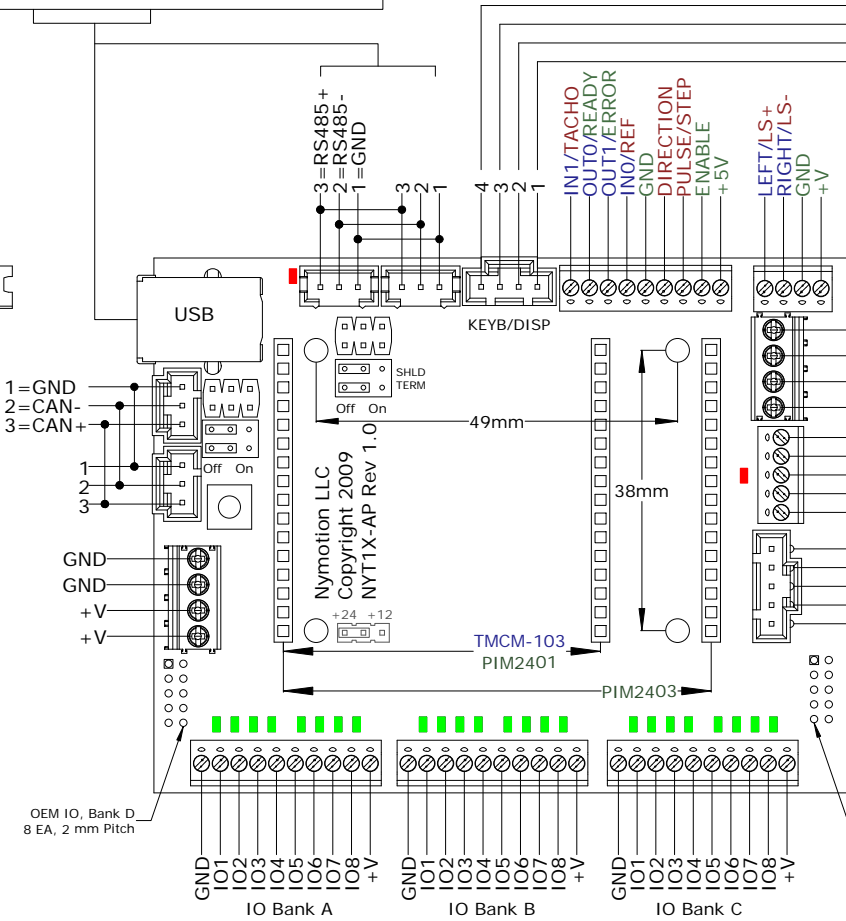
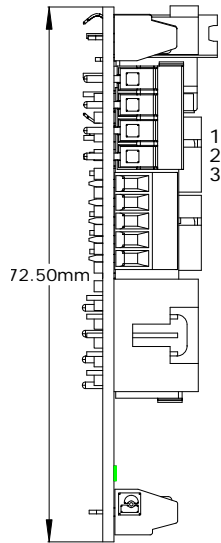
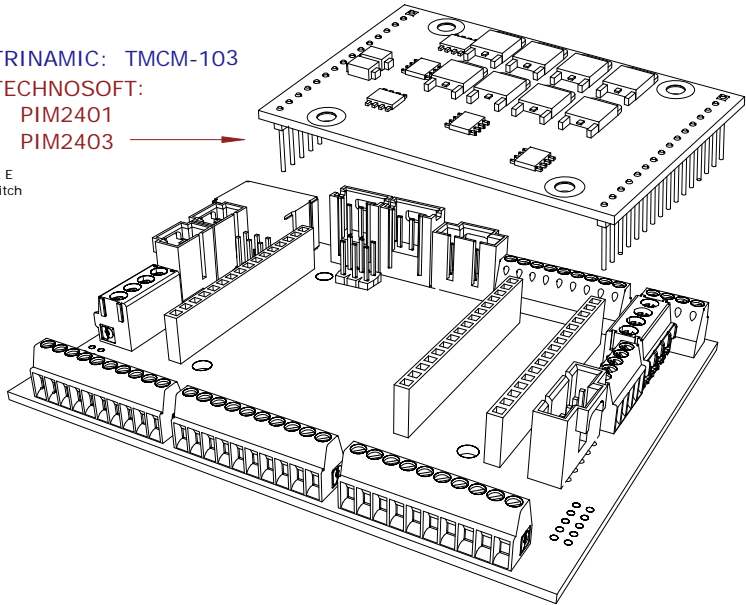

1 = GND
2 = CAN-
3 = CAN+

OEM IO, Bank D
8 EA, 2 mm Pitch

OEM IO, Bank E
8 EA, 2 mm Pitch

GND IO1 IO2 IO3 IO4 IO5 IO6 IO7 IO8 +V
IO Bank A

GND IO1 IO2 IO3 IO4 IO5 IO6 IO7 IO8 +V
IO Bank B

GND IO1 IO2 IO3 IO4 IO5 IO6 IO7 IO8 +V
IO Bank C