

HOST Application: LabView, VB, C++ ...  
 Commands: 1HOME, 2DOWN, 3SCAN,100 (ms)

**NYT1X-AP Rev 1.0**  
 Nymotion LLC

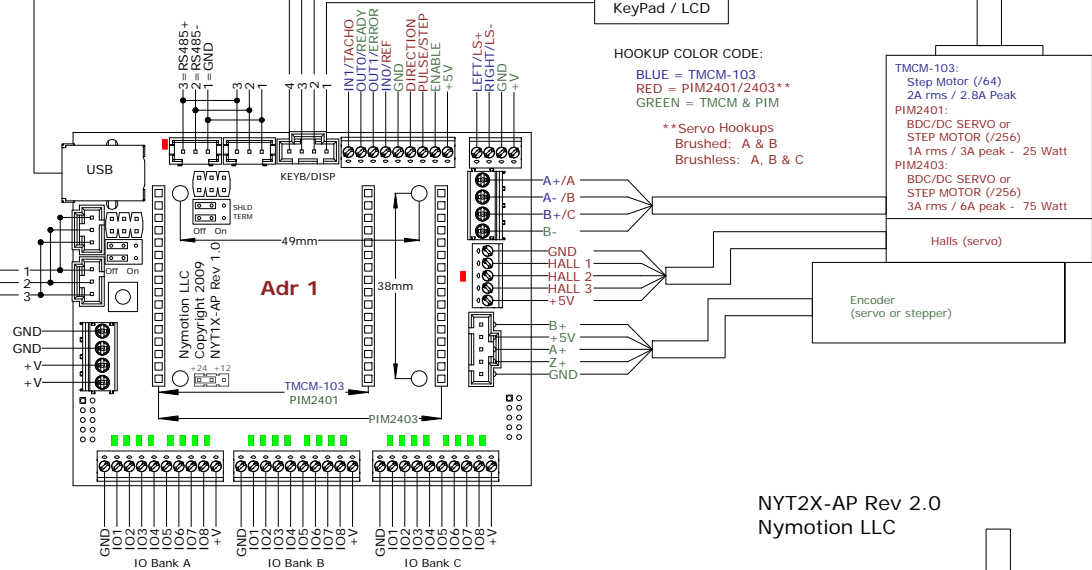

**NYT2X-AP Rev 2.0**  
 Nymotion LLC

