

HOST Application
Hyperterminal, VB, LabView, C++, C# ...

Custom MMI
KeyPad / LCD

NYT2X-AP Rev 2.0

Nymotion LLC

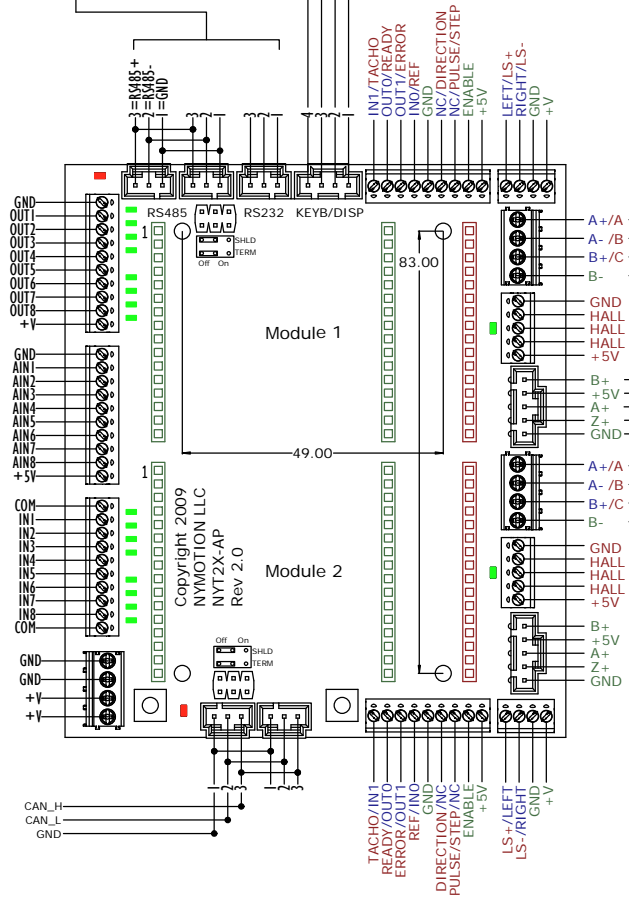
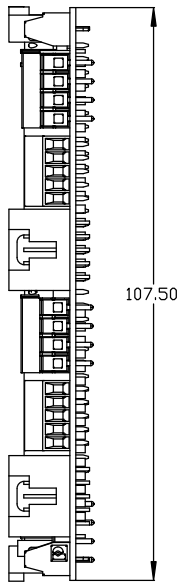

HOOKUP COLOR CODE:
 BLUE = TCMC-103
 RED = PIM2401/2403**
 GREEN = TCMC & PIM

** Servo Hookups
 Brushed: A & B
 Brushless: A, B & C

TCMC-103:
Step Motor (/64)
2A rms / 2.8A Peak

PIM2401:
BDC/DC SERVO or
STEP MOTOR (/256)
1A rms / 3A peak - 25 Watt

PIM2403:
BDC/DC SERVO or
STEP MOTOR (/256)
3A rms / 6A peak - 75 Watt

Halls (servo)

Encoder
(servo or stepper)

